

Chapter 4 – Street Drainage System Design

4.1 Purpose

Urban streets not only carry traffic, but stormwater runoff as well. However, water on a street can create hydroplaning effects, and can severely impact the traffic flow and the safety of travelers. For these reasons, a street drainage system must be properly designed to quickly remove stormwater from the traffic lanes. Street drainage includes both minor and major drainage systems. A minor system consists of street inlets and storm sewers, which can handle minor storm events. During a major storm event, street gutters and roadside ditches operate like wide and shallow channels to carry the flooding water away.

This chapter summarizes the procedures for street drainage system designs, including street hydraulic allowable capacity, street inlet sizing, and storm sewer design and flow analyses. The design methods presented in this chapter are referenced to the Hydraulic Engineering Circulation 22 published by Federal Highway Administration (FHA HEC22) and Chapter 6 in the Urban Stormwater Drainage Criteria Manual, Urban Drainage and Flood Control District, Denver, Colorado (USWDCM 2001, UDFCD).

4.2 Design Storms

As stated above, a street drainage system consists of minor and major systems. While street inlets and sewers are designed to intercept minor storm events, street gutters and roadside swales are, in fact, part of the major drainage system that is capable of passing the storm runoff from major storms. During a major storm event, the excess stormwater will accumulate in and be carried through the street gutters.

Proper street drainage design requires that public safety be maintained and any flooding be managed to minimize flood damage. Wherever the spread or pooling of water on the street exceeds the allowable spread, an inlet must be placed. Street inlets intercept surface runoff and transfer the water into the sewer system. **Table 4.1** presents City of Aspen's requirements established for the level of protection in terms of storm return periods for the minor and major street drainage systems.

4.3 Street Classifications

For purposes of street drainage system design, streets in the City of Aspen are classified into alleys, local, commercial and collector streets and typically match the following descriptions.

An alley is a narrow street that usually runs through the middle of a block giving access to the rear of lots or buildings and is typically not intended for general traffic circulation. Alleys in Aspen are inverted (center is lower than sides) and approximately 20 ft wide. They are typically gravel in the residential areas and paved in the commercial areas.

Local streets in the City of Aspen are designed to provide traffic service for residential areas. They may have stop signs and are characterized by two moving traffic lanes that are 11-ft wide in each direction. The street cross-section is symmetrical to the street crown with a transverse slope across the traffic lanes ranging from 2 to 3.5%, increasing to 4% across the parking lane which is 8 feet wide. In a rural setting, road side ditches collect the street runoff without curbs and gutters.

Residential/Collector streets in the City of Aspen are designed to provide service to residential areas and to serve the main thoroughfares of the City. An example of a residential/collector street is Cemetery Lane. The cross section of a residential/collector street is similar to a local street, except that there is potentially a parking lane – width is 8 feet for parallel parking or 18 feet for head-in parking at an angle.

Commercial streets in the City of Aspen are designed to provide service to business areas. A commercial street provides two moving traffic lanes of a minimum of 11 feet wide in each direction. The street cross-section is symmetrical to the street crown with a transverse slope varied from 2 to 4% across the traffic

lanes. Parking lanes are adjacent to the curbs and gutters. There is a landscaping strip 6 feet or wider between sidewalks and parking lanes.

Cross-section drawings of standard street sections can be found in the most recent edition of the City of Aspen Engineering Department’s Design and Construction Standards.

4.4 Design Considerations for Street Drainage

Water spread on the street hinders traffic flow and can become hazardous due to water splash and hydroplaning, and certain design considerations must be taken into account in order to meet street drainage objectives. **Table 4.1** lists the design criteria to keep the water spread on the street within the allowable limits during a minor or major storm event. Basically, all street gutters or ditches in the City of Aspen must be able to handle the minor event storm without overtopping the curb(s) or swale(s) and without inundating the sidewalks or crowns of the road. Residential and Commercial streets in the City of Aspen need to maintain at least one-lane width in the middle of the street for each traffic direction free from stormwater to allow for emergency use. Standards for major storm drainage designs are also required. The major storm runoff on the street needs to be assessed to determine the potential for flooding and public safety.

Table 4.1 Minor and Major Street Systems Design Return Periods and Allowable Spread

Drainage System	Level of Protection (Return Period in years)			
	Commercial Street	Residential/Collect or Street	Local Street	Alley
Minor System	10	10	5	5
Maximum Water Spread during a Minor Event	No curb overtopping. Flow spread must leave at least one lane free from water for both traffic directions	No curb overtopping. Flow spread must leave at least one lane free from water for both traffic directions	Flow may spread to crown of street	The depth of water cannot exceed 12 in. in the low point or cause inundation of adjacent buildings
Major System	100	100	100	100
Maximum Water Depth during a Major Event	The depth of water should not exceed the street crown to allow operation of emergency vehicles. The depth of water over the gutter flow line should not exceed 12 in or cause inundation of adjacent buildings	The depth of water over the gutter flow line should not exceed 12 in. or cause inundation of adjacent buildings	The depth of water over the gutter flow line should not exceed 12 in. or cause inundation of adjacent buildings	The depth of water cannot exceed 12 in. in the low point or cause inundation of adjacent buildings

It is the responsibility of the property owner to protect their property from street drainage and to maintain the street’s ability to carry floodwaters. Property owners should establish a vertical grade 6 inches from the top of the curb or 12 inches from the street surface to maintain the appropriate capacities of the streets.

Since it is more economic to continue accumulating gutter flow across a street intersection, not every street corner needs an inlet unless the water spread will be wider than what is allowable. In the City of

Aspen, a cross flow is allowed at a street intersection if it does not create hazards to traffic movement and pedestrians. The dimension of a cross pan is illustrated in **Figure 4.1**.

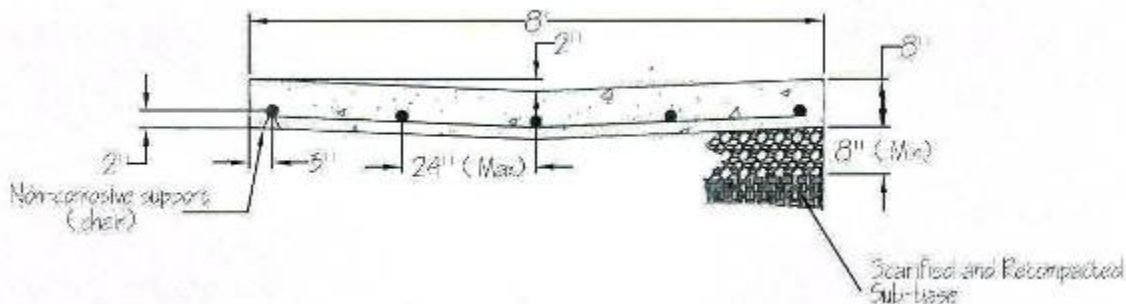

Figure 4.1 Cross Pan

4.5 Street-Side Swale

Swales are designed to collect runoff from streets and transport stormwater to the nearest inlet or major waterway. Most often swales are used in rural areas or on local streets in the City of Aspen because those streets are not equipped with curb and gutter sections. However, curbsless streets with swales are encouraged where possible because of the systems' effectiveness in reducing runoff and pollutant loadings. This system allows street runoff a chance to infiltrate into the soils and be filtered by vegetation before reaching hard infrastructure or the City's waterways. More information about the water quality benefits and the design of road side swales can be found in the Water Quality Chapter of this Manual. **Figure 4.2** illustrates a swale design.

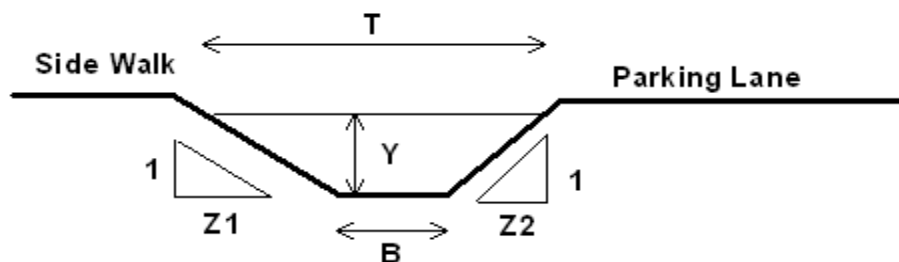

Figure 4.2 Typical Swale Cross-section

To calculate the capacity of a swale refer to the worksheet included in Appendix C or use the following set of equations:

$$T = (Z_1 + Z_2)Y \tag{Equation 4-1}$$

$$A = \frac{1}{2}(T + B)Y \tag{Equation 4-2}$$

$$P = \sqrt{1 + Z_1^2} + \sqrt{1 + Z_2^2} + B \tag{Equation 4-3}$$

$$R = \frac{A}{P} \tag{Equation 4-4}$$

$$Q = \frac{1.489}{N} A^{5/3} P^{-2/3} \sqrt{S_o} \quad \text{(Equation 4-5)}$$

Where Z_1 = left side slope, Z_2 = right side slope, B = bottom width (ft), Q = flow rate (cfs), N = Manning's roughness coefficient, A = flow area (ft²), T = top width (ft), R = hydraulic radius (ft), P = wetted perimeter (ft), and S_o = longitudinal slope (ft/ft).

Considering public safety and maintenance, swales shall be designed with limitations on flow velocity, depth, and cross-slope geometries. The following limitations shall apply to street-side swales:

- Maximum 100-year flow velocity = 7.0 ft/sec to avoid severe erosion
- Maximum 100-yr depth = 2 feet
- Minimum side slope for each side = 4H:1V. to stabilize the banks

Under no circumstances shall a street-side swale have a longitudinal slope steeper than that of the adjacent street. Use proper linings or grade control checks to satisfy the design criteria.

4.6 Gutter Design

4.6.1 Street Gutter Flow

The street hydraulic capacity for a local or collector street in the City of Aspen is dictated by the allowable water depth in the gutter or the allowable water spread across the traffic lane. In practice, a gutter depression, D_s , of 2 inches is introduced at the street curb in order to increase the gutter conveyance capacity. The dimensions of a curb-gutter unit used in the City of Aspen are illustrated in **Figure 4.3** in which R1" means a radius of 1 inch to define the curve surfaces.

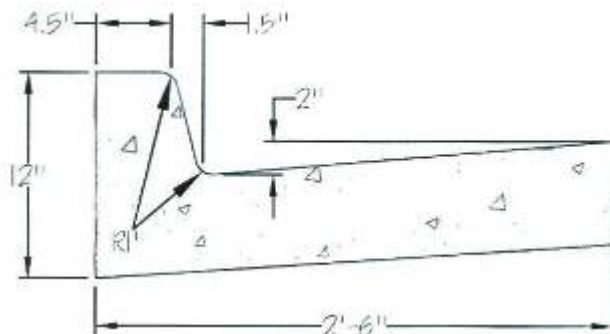

Figure 4.3 Catch Type – Curb and Gutter Unit

Figure 4.4 illustrates a typical street and gutter cross section. Stormwater flow carried in a street gutter can be divided into *gutter flow*, Q_w , and *side flow*, Q_x . The gutter flow is the amount of flow carried within the gutter width, W , and the side flow is the amount of flow carried by the water spread, T_x , encroaching into the traffic lanes.

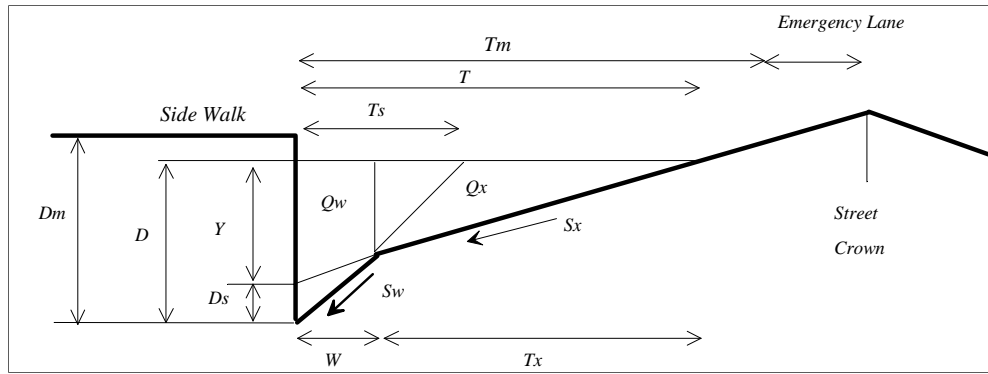

Figure 4.4 Street and Gutter Cross-Section for a Local or Collector Street (Not Drawn to Scale)

Where

- W = gutter width (2.5 ft for the City of Aspen),
- D_s = gutter depression (2 inches),
- S_x = street transverse slope (2% or 4% for the City of Aspen)
- S_w = gutter cross slope
- D = water depth at curb face = Y + D_s
- T_s = water spread in feet for water depth, D, in the gutter
- T_x = side flow width
- Q_x = side flow in cfs,
- Q_w = gutter flow in cfs,
- n = surface roughness coefficient of 0.016.

In Aspen, the minimum gutter grade shall be 0.75%. The minimum cross-slope on all streets shall be 2.0% and may vary from 2.0% to 4.0%. The street and gutter section having the most restrictive capacity (steepest cross-slope) shall be used for design.

Applying the open channel flow theory to the gutter and side flows yields:

$$Q_x = \frac{0.56}{n} S_x^{1.67} T_x^{2.67} \sqrt{S_o} \tag{Equation 4-6}$$

$$Q_w = \frac{0.56}{n} S_w^{1.67} [T_s^{2.67} - (T_s - W)^{2.67}] \sqrt{S_o} \tag{Equation 4-7}$$

The total flow, Q, on the street is the sum as:

$$Q = Q_x + Q_w \tag{Equation 4-8}$$

The flow cross sectional area for a composite street is calculated as:

$$A = \frac{YT + WD_s}{2} \tag{Equation 4-9}$$

4.6.2 Allowable Street Hydraulic Capacity

Street hydraulic capacity is dictated by the allowable gutter depth or the allowable water spread across the traffic lanes, whichever is smaller. To calculate the water depth at the curb face, D , and the corresponding spread, T_s , see equations in **Appendix B**. The allowable water depths in the street gutter are described in **Table 4.2** for a minor and major event. The allowable water spread is determined with consideration of emergency vehicle needs during a storm event (Agrawal, et al, 1977). In addition to water flow depth and spread, water flowing on a steep street can develop a high speed and imposes a significant impingement force on vehicles and pedestrians. As recommended (USWDCM 2001, UDFCD), the street gutter-full capacity is subject to flow reduction. Using the product of flow velocity and water depth, flow reduction factors are derived for both minor and major storm events for the City of Aspen (Guo 2000). As illustrated in **Figure 4.5**, the steeper the street is, the higher the flow reduction factor must be.

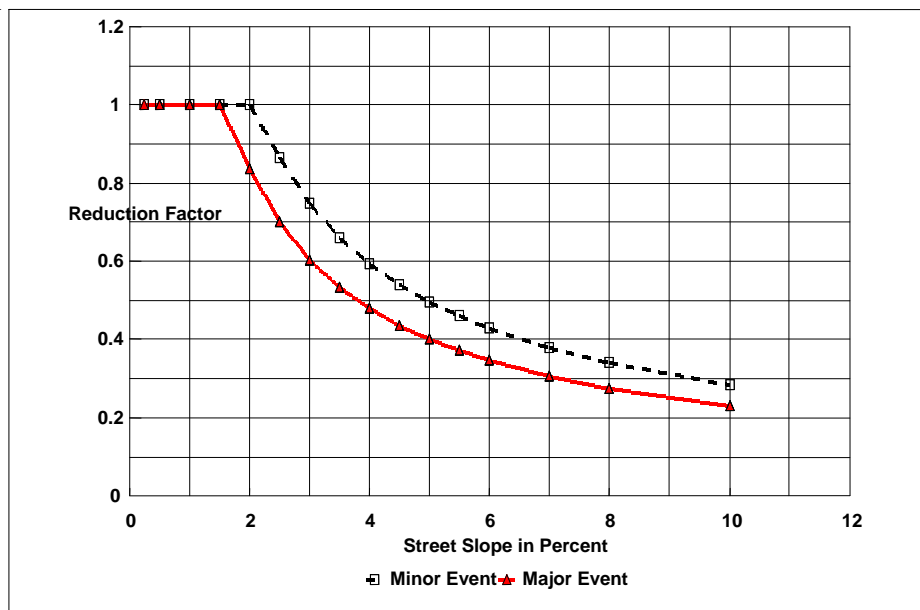

Figure 4.5 Flow Reduction Factors for Street Flow

To calculate the allowable street hydraulic capacity (ASHC), Q_a :

$$Q_a = \min(R \times Q_g, Q_m) \tag{Equation 4-10}$$

In which Q_a = ASHC in cfs, Q_g = gutter full capacity in cfs, R = flow reduction factor, and Q_m = spread-width capacity in cfs.

For derivations of gutter flow equations and calculated example problems see Appendix C.

4.7 Inlet Functions

Stormwater inlets are a vital component of the urban stormwater collection and conveyance system. Inlets collect excess stormwater from the street, transition the flow into storm sewers, and can provide maintenance access to the storm sewer system. They can be made of cast iron or concrete and are installed on the edge of the street adjacent to the street gutter, or in the bottom of a swale. Roadway geometrical features often dictate the location of pavement drainage inlets.

4.7.1 Inlets

In general, inlets are placed at all low points (sumps or sags) such as median breaks, intersections, and crosswalks. The spacing between two adjacent inlets is governed by the allowable street hydraulic capacity (ASHC). In other words, the street inlets are so spaced that the design flow on the street is close to, but not exceeding, the ASHC for the minor storm event. There are four major types of inlets: grate, curb opening, combination, and slotted. Example inlets are shown in **Figures 4.6 – 4.8**. In Aspen, type R inlets are generally not permitted. Type R curb openings or combination inlets must receive approval from the City Engineer.



Figure 4.6 Grate Inlet used in City of Aspen



Figure 4.7 Curb Opening Inlet used in City of Aspen



Figure 4.8 Trench Drain (Slotted Inlet) in City of Aspen

4.7.2 General Design Guidelines

The following guidelines shall be used when designing inlets along a street section:

1. Design and location of inlets shall take into consideration pedestrian and bicycle traffic. All inlet grates shall be pedestrian and bicycle-safe.
2. Maintenance of inlets shall be considered when determining inlet locations. The slope of the street, the potential for debris and ice accumulations, the distance between inlets and/or manholes etc., shall be considered. Maintenance access shall be provided to all inlets.
3. Pedestrian safety in winter months, when snow banks begin to melt, needs to be considered. To prevent standing water in the pedestrian travel way, inlets must be located directly upgradient and downgradient (i.e. flanking inlets) of ADA ramp access to sidewalks
4. To avoid potential damage from large vehicles driving over the curb return, inlets shall not be placed in the curb return radii.
5. Selection of the appropriate inlet grate shall be based on a number of factors, including, but not limited to, the adjacent land use and potential for pedestrian or bicycle traffic, the potential for debris accumulation, visibility, expected loading from vehicles, and hydraulic capacity.
6. Consideration should be given to flanking inlets on each side of the low point when the depressed area has no outlet except through the system. The purpose is to provide relief if the inlet at the low point becomes clogged. Consult HEC-22 for additional information regarding this concept.
7. In many cases, inlets are necessary at grade breaks, where street or ditch grades change from steep to relative flat because of the reduced conveyance capacities. In addition, it is common for icing or sediment deposition to occur with nuisance flows in reaches where the grades are relatively mild.

4.7.3 Inlet Clogging

The proper operation of an inlet is subject to clogging by urban debris, which can vary by location and season. To be conservative, a clogging factor of 50% is recommended for a single grate and 12% for a single curb opening inlet. For an inlet with multiple units, the clogging factor declines as the number of inlet units increases. **Table 4.4** lists the recommended clogging factors for inlets with multiple units.

Table 4.2 Clogging Factors for Inlet Design

Number of Inlet Units	Clogging Factor - Curb-Opening Inlet	Clogging Factor - Grate Inlet
1	0.12	0.50
2	0.08	0.38
3	0.05	0.29
>4	0.04	0.23

The interception capability of an on-grade inlet is proportional to the inlet wetted length, and an in-sump inlet is proportional to the inlet opening area. Therefore, the effective length of an on-grade inlet is calculated as:

$$L_e = (1 - C_g)L \quad \text{(Equation 4-11)}$$

in which L = total wetted length, C_g = clogging factor selected for the number of inlet units, and L_e = effective (unclogged) length. Similarly, the effective opening area of an in-sump inlet is calculated as:

$$A_e = (1 - C_g)A \quad \text{(Equation 4-12)}$$

in which A = total opening area, and A_e = unclogged opening area.

4.7.4 Design Flow on Street

Often an on-grade inlet is designed to capture 70 to 90% of the street flow. The by-pass flow will be carried over to the next downstream inlet. The design flow, Q_s , at an inlet location is the sum of the local flow, Q_p , contributed from the local area and the carry-over flow, Q_{co} , from the immediately upstream inlet.

$$Q_s = Q_p + Q_{co} \quad \text{(Equation 4-13)}$$

4.7.5 On-Grade Grate Inlet

Stormwater carried in the street includes the gutter flow that is carried within the gutter width, and the side flow that is spread into the traffic lanes. In general, the gutter flow within the gutter width can be completely intercepted by the inlet. The interception percentage, R_x , of the side flow is estimated as:

$$R_x = \frac{1}{\left(1 + \frac{0.15V^{1.8}}{S_x L_e^{2.3}}\right)} \quad \text{(Equation 4-14)}$$

As a result, the total interception capacity, Q_i , for the grate inlet is equal to

$$Q_i = Q_w + R_x Q_x \quad \text{(Equation 4-15)}$$

The carry-over flow, Q_{co} , is the difference between Q_s and Q_i as:

$$Q_{co} = Q_s - Q_i \quad \text{(Equation 4-16)}$$

4.7.6 In-Sump Grate Inlet

A grate inlet in a sump can operate like a weir under a shallow water depth. Its weir-flow capacity is estimated as:

$$Q_w = C_w P_e Y_s^{1.5} \quad \text{(Equation 4-17)}$$

in which Q_w = weir-flow capacity in cfs, C_w = weir coefficient such as 3.0 for feet-second units, Y_s = water depth in ft, and P_e = effective weir length in feet around the inlet grate defined as:

$$P_e = (1 - C_g)P \quad \text{(Equation 4-18)}$$

When a grate is submerged and operates like an orifice, its orifice-flow capacity is estimated as:

$$Q_o = C_o A_e \sqrt{2gY_s} \quad \text{(Equation 4-19)}$$

$$A_e = (1 - C_g)mW_o L_o \quad \text{(Equation 4-20)}$$

in which C_o = orifice coefficient (this coefficient relates the wetted perimeter of the grate, P , to the effective perimeter P_e , that acts as a weir; the recommended value for C_o for most applications is 0.65), g = gravitational acceleration (32.2 ft/sec^2), W_o = grate width in ft, L_o = grate length in ft, and m = area opening ratio on the grate. The transition between weir flow and orifice flow is not clearly understood. Theoretically, the change in the hydraulic performance of a grate occurs at a depth where the weir rating curve intersects the orifice rating curve. In practice, for a specified water depth, the interception capacity of an inlet grate is the smaller of Q_w and Q_o .

4.7.7 On-Grade Curb Opening Inlet

To install a curb opening inlet on a continuous grade, the required curb opening length, L_t , for complete (100%) interception of the design storm runoff, Q_s , on the street is computed by:

$$L_t = 0.60Q^{0.42}S_o^{0.30}\left(\frac{1}{nS_e}\right)^{0.6} \quad \text{(Equation 4-21)}$$

$$S_e = S_x + S_w \frac{Q_w}{Q_s} \quad \text{(Equation 4-22)}$$

in which L_t = required length for 100% interception, S_o = street longitudinal slope, n = Manning's roughness of 0.016, and S_e = equivalent transverse street slope. The curb-opening inlet shall have a length less than, but close to, L_t . The interception capacity of a curb-opening inlet is calculated as:

$$Q_i = Q \left[1 - \left(1 - \frac{L_e}{L_t} \right)^{1.80} \right] \quad \text{(Equation 4-23)}$$

in which Q_i = inlet capacity, and L_e = effective length of the curb opening inlet.

4.7.8 In-Sump Curb-Opening Inlet

Referring to **Figure 4.9**, a curb-opening inlet in a sump operates like a weir. Its interception capacity is estimated as:

$$Q_w = C_w P_e Y_s^{1.5} \quad \text{(Equation 4-24)}$$

$$P_e = (1 - C_g)(L + kW_p) + 2W \quad \text{(Equation 4-25)}$$

in which P_e = effective weir length around the depression pan in front of the curb opening inlet, W_p = width of depressed pan, and $k = 1.8$ for two sides of the pan in **Figure 4.9**. When the water gets deeper, a curb opening inlet operates like an orifice that can be modeled as:

$$Q_o = C_o A_e \sqrt{2g(Y_s - Y_c)} \quad \text{(Equation 4-26)}$$

$$A_e = (1 - C_g)HL \quad \text{(Equation 4-27)}$$

in which Y_s = water depth, Y_c = center of opening area above the ground, H = height of opening area, L = width of opening area. The center of the curb opening area is the vertical distance above the flow line. It

is important that the thickness of the concrete cover be included in the calculation of the depression of the curb opening.

It is not well understood how an in-sump curb opening inlet switches from weir to orifice flow. In practice, for a specified water depth, the interception capacity of an in-sump inlet is dictated by the smaller value of the weir or the orifice flows.

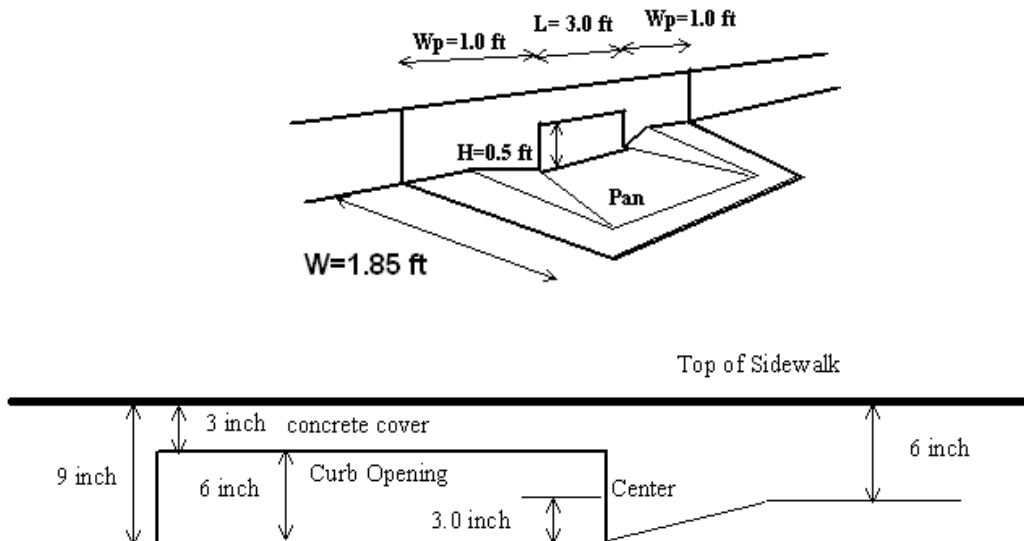

Figure 4.9 Example of Curb Opening Inlet in Sump

4.7.9 Slotted Inlet

A slotted inlet is similar hydraulically to a curb-opening inlet. As a result, design formulas developed for curb-opening inlets are also applicable to slotted drain inlets. In the City of Aspen, trenches are often used as a slotted inlet. The interception capacity of a trench is similar to the slotted inlet while the conveyance capacity of a trench is calculated using the ditch flow formulas, **Equation 4.1** through **4.5**.

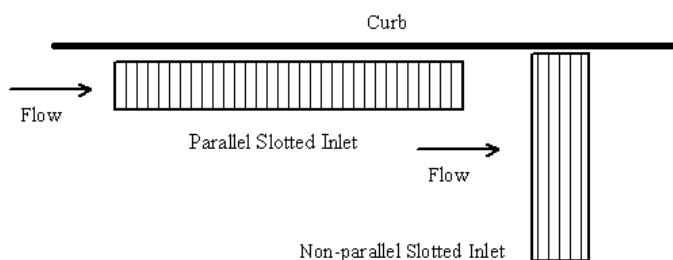

Figure 4.10 Slotted Inlet

4.7.10 Combination Inlet

A combination inlet, shown in **Figure 4.11**, is formed with a curb opening and a grate inlet. During a storm event, if one inlet is clogged, the other can still function. Empirical formulas for sizing an inlet were developed under the assumption that each inlet operates independently, although the interference between the grate inlet and the curb opening inlet in a combination inlet has not been fully investigated yet. The assumption of independent operation implies that the curb-opening inlet is placed immediately

downstream of the grate inlet. In other words, the curb-opening inlet receives the carryover flow from the grate inlet. In the case of 100% interception by the grate, the curb opening inlet will intercept no flow at all. In theory, the capacity of a combination inlet is less than the sum of the interception for both inlets. To be conservative, the capacity of a combination inlet is assumed to be the higher value of either the grate or the curb-opening inlet when the water depth is shallow (<6 inches) (Guo, 1996). The assumption that both inlets can work independently may be justified when the water depth is greater than the curb-opening height.

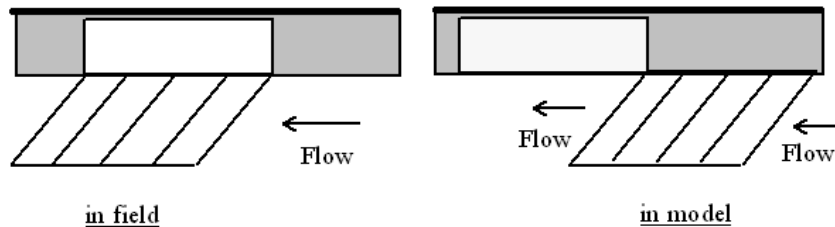

Figure 4.11 Assumptions Regarding Flow Interception by a Combination Inlet

For examples calculating inlet design, see Appendix C.

4.8 Storm Sewers

The storm sewer system is comprised of inlets, pipes, manholes, bends, outlets, and other appurtenances. The stormwater passes through these components and is discharged into a downstream water quality enhancement facility before draining into a natural water body. The plan layout and vertical profile of a storm sewer system are governed by following factors as:

- street alignment for the sewer line
- street inlet placement
- existing utility locations
- sewer system outfall location and tailwater elevation

4.8.1 Manholes

Manholes are generally made of pre-cast or cast-in-place reinforced concrete. They are typically 4 feet in diameter. Manholes and junctions are used in sewer systems to provide a hydraulically efficient transition at alignment changes along a sewer line. Manholes and junctions are also used to provide access to storm sewers for maintenance purposes. To maintain hydraulic efficiency and adequate maintenance access, a manhole shall be located at any of the following points:

- where the pipe size changes
- where the direction of sewer line changes
- where the invert grades along the sewers change
- where drops are added to the vertical profile
- in conjunction with all laterals
- where the lateral is not easily accessible for maintenance from the inlet
- where the spacing between manholes exceeds 400 feet

4.8.2 Design Procedure and Constraints

The design of a storm sewer system requires basic data in the proposed service area, including topography, drainage boundaries, soil types, and locations of any existing storm sewers, inlets, and manholes. In addition, identification of the type and location of other utilities is necessary. Design of a sewer system begins with the placement of inlets and manholes. The vertical profile for the proposed sewer line can be approximated using the street profile as a reference. Considering a minimum of 7-ft soil cover, the sewer crowns may be set 7 feet or greater below the ground surface. Manhole drops can be introduced to reduce the water flow velocity or to avoid utility conflicts. The sewers are sized from the most upstream manhole to the system exit as the flow rate and flow time are accumulated along the sewer network. At a manhole, the longest flow time among all incoming flow paths shall be used to calculate the design rainfall intensity. The Rational method is recommended to estimate the peak flow at the manhole and the Manning's formula, Equations 4.1 through 4.5, is suitable to size the outgoing sewer from the manhole. The calculated pipe diameter is often not commercially available. As a result, the next larger commercial pipe size shall be adopted. After all sewers are sized by open channel flow under the normal flow condition, the sewer system is further subject to a performance evaluation under a given tailwater at the system exits. The energy and hydraulic grade lines will predict if any manholes in the sewer system are surcharged.

The sewer design can be finalized by continuously adjusting sewer sizes and manhole drops until all the design criteria and constraints are satisfied, including:

- permissible flow velocity in a sewer between 2 and 18 fps for the selected pipe material and slope.
- minimum earth coverage of 7 feet, for the cold climate in the Aspen area,
- minimum sewer diameter of 18 inches for sewer trunks and 15 inches for lateral lines.
- minimum manhole drop of 0.20 foot, and
- maximum manhole spacing of 400 feet.

To accommodate back water effects, a sewer shall be sized so that the normal design depth does not exceed 80% of the diameter of a circular pipe or the height of a box sewer. Since the design discharge in a sewer system increases downstream, sewer sizes in a system must increase downstream as well. Decrease in sewer size due to steep invert slope or smooth pipe roughness must be avoided.

4.8.3 Design Flow at Manhole

A manhole is treated as a design point where the system flow from the upstream tributary area is combined with the local flows from the local tributary areas. There are two ways to compute the design flow at a manhole.

Design Flow Using Rational Method

To model the accumulation of flows along the sewer line, all manholes and sewers are converted into nodes and links. Sewer sizing starts from the most upstream manhole. At the n-th node, the local area is combined with the accumulated area in the system as:

$$(A_e)_n = C_n A_n + \sum_{i=1}^{i=n-1} C_i A_i \quad \text{(Equation 4-28)}$$

The accumulated travel time through the sewer line is:

$$(T_c)_n = (T_c)_{n-1} + \frac{L_n}{60V_n} \quad \text{(Equation 4-29)}$$

in which A_e = effective contributing area in acres, T_c = accumulated time of concentration in minutes, L = sewer length in feet, V = sewer flow velocity in fps, i = i -th node upstream of the design point, and n = n -th node at the design point. Set the design rainfall duration equal to T_c to calculate the peak flow using the Rational Method.

Design Flow with Known Local Flow

This approach can be used in the case that the local flow at the manhole is specified by the hydrologic report, or provided as a quantified off-site input to the sewer system. The inherent time of concentration, T_a , for this known local flow, Q_a , can be calculated using the local area, A_a , and runoff coefficient, C_a , as:

$$i = \frac{Q_a}{C_a} = \frac{19P_1}{(10 + T_c)^{0.789}} \quad \text{(Equation 4-30)}$$

Equation 4-30 will then be incorporated into the accumulation process of flow time through the sewer line for continuous peak flow calculations using the Rational Method.

4.8.4 Sewer Sizing – Circular, Box, and Arch Pipes

Circular Sewer Hydraulics

Equation 4-43 can be applied to determine the minimum diameter, d , required to accommodate a design flow, Q , in a pipe flowing full under gravity (normal) flow conditions using Manning's equation.

$$d = \left(\frac{nQ}{K\sqrt{S_0}} \right)^{\frac{3}{8}} \quad \text{(Equation 4-31)}$$

Where Q = design flow in cfs, S_0 = conduit invert slope in ft/ft, d = hydraulically required circular diameter in feet (full flow assumed), and $K = 0.462$ for feet-second units. The calculated pipe size is often not commercially available. As a result, the next larger commercially available pipe size shall be used. This will result in partially-full flow. To determine the depth for partially-full flow (to check against 80% criterion under normal flow conditions), the following procedure can be used:

1. Calculate Q_{full} for the actual pipe diameter using Manning's equation,
2. Calculate the ratio of Q_{design}/Q_{full} ,
3. Look up d/D_{full} value corresponding to Q_{design}/Q_{full}
4. Calculate depth, $d = d/D_{full} * \text{pipe diameter}$.

For larger commercially-available pipe, use the nomograph or tabular procedure for evaluating partially full flow conditions.

Arch (Elliptical) Sewer Hydraulics

The limited clearance due to existing underground utilities often sets constraints to the sewer profile. Between two manholes, a flat and wide sewer may fit the narrowed corridor. As a result, an elliptical or arch pipe is sometimes selected as a replacement for a circular pipe. The flow through an elliptical or arch pipe in **Figure 4.12** is dictated by the cross-sectional geometry. For simplicity, an equivalent circular pipe may be used as an approximation in hydraulic computations.

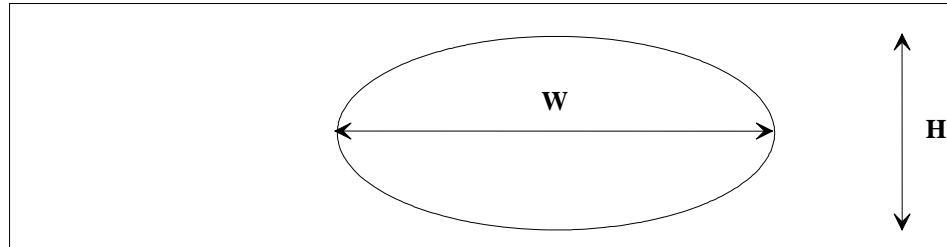

Figure 4.12 Elliptical Sewer

The equivalent diameter is approximated by

$$d = 0.5(H + W) \quad \text{(Equation 4-32)}$$

in which H = rise of the arch sewer and W = span of the arch sewer

Box Sewer Hydraulics

When a box sewer is selected, the width of the box sewer must be specified first. The hydraulic calculation is to provide the flow depth. As illustrated in **Figure 4.13**, the hydraulic parameters in a box sewer are related to the flow depth as:

$$A = BY \quad \text{(Equation 4-33)}$$

$$P = 2Y + B \quad \text{(Equation 4-34)}$$

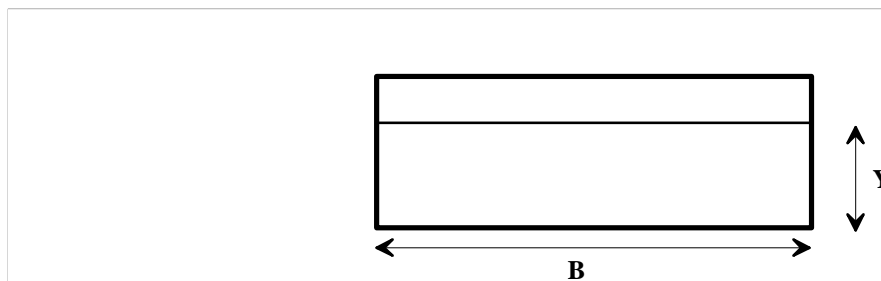

Figure 4.13 Box Sewer

4.8.5 Sewer Energy and Hydraulic Grade Lines

The Energy Grade Line (EGL) represents the energy slope between the two adjacent manholes in a storm sewer system. A manhole may have multiple incoming sewers, but only one outgoing sewer. Each sewer and its upstream manhole form a sewer and manhole unit. The entire storm sewer system can be decomposed into a series of sewer & manhole units. Each unit has to satisfy the energy principle. The computation of energy grade line (EGL) is a repetition of the energy balance process through each sewer and manhole unit.

$$H_1 + \frac{V_1^2}{2g} = H_2 + \frac{V_2^2}{2g} + H_f + H_m \quad \text{(Equation 4-35)}$$

Where H = water surface elevation at manhole, V = flow velocity through sewer, H_f = friction loss through the sewer pipe, and H_m = juncture losses at manhole. The subscript "1" represents the upstream manhole and "2" represents the downstream manhole.

The flow in a sewer pipe can be either, or a combination of: open channel flow, surcharged flow, or pressurized flow. When a free surface exists through the pipe length, open channel hydraulics shall be applied to the backwater surface profile computations. The friction loss through the sewer pipe is the cumulative head losses through the specified type of water surface profile. For instance, the sewer pipe carrying a subcritical flow may have an M-1 water surface profile if the downstream manhole is almost surcharged or an M-2 water surface profile if the downstream manhole is not surcharged.

On the other hand, a pipe carrying a supercritical flow may have an S-2 water surface profile if the downstream manhole is not submerged. Otherwise, a hydraulic jump may be expected.

When the downstream sewer crown is submerged to a degree that the entire sewer pipe is under the hydraulic grade line, the head loss for this flowing-full condition is estimated by pressure flow hydraulics.

When the downstream sewer crown is slightly submerged, the downstream end of the sewer pipe is surcharged, but the upstream end of the sewer pipe can remain as open channel flow. The head loss during surcharge flow depends on the flow regime. For a subcritical flow, the head loss is the sum of the friction losses for the flowing-full flow and for the open channel flow. For a supercritical flow, the head loss may involve a hydraulic jump. As a result, the culvert hydraulic principles can be used to calculate both inlet and outlet control conditions; whichever is higher dominates the final results.

4.9 References

Akan, A.O. and R.J. Houghtalen. 2002. *Urban Hydrology, Hydraulics, and Water Quality*. Prentice Hall Upper Saddle River, NJ.

Federal Highway Administration (FHWA). 1984. *Drainage of Highway Pavements*. Hydraulic Engineering Circular 12, Federal Highway Administration, McLean, VA

Federal Highway Administration (FHWA). 1996. *Urban Drainage Design Manual*. Hydraulic Engineering Circular 22, Federal Highway Administration, Washington, DC

Guo, J.C.Y. 1998a. *Storm Sewer System Design and Flow Analysis Using the Personal Computer Model UDSEWER*. Urban Drainage and Flood Control District. Denver, CO

Guo, J.C.Y. 1998b. *Street Hydraulics and Inlet Sizing Using the Computer Model UDINLET*. Urban Drainage and Flood Control District. Denver, CO

Guo, J.C.Y. 1999. *Storm Water System Design*. CE 5803, University of Colorado at Denver, CO

Guo, J.C.Y. 2000a. Design of Grate Inlets with a Clogging Factor. *Advances in Environmental Research* 4(3)181-186.

Guo, J.C.Y. 2000b. Street Storm Water Conveyance Capacity. *Journal of Irrigation and Drainage Engineering* 136(2)119-124.

Guo, J.C.Y. 2000c. Street Storm Water Storage Capacity. *Journal of Water Environment Research*, Vol. 27, No. 6. Sept/Oct.

Guo, James C.Y. 2006. *Decay-based Clogging Factor for Curb Inlet Design*, Vol 132, No. 11, ASCE J. of Hydraulic Engineering, November.

USWDCM 2001. Urban Stormwater Design Criteria Manual, Volume 2, published by Urban Drainage and Flood Control District, Denver, CO.

Wright-McLaughlin Engineers. 1969. *Urban Storm Drainage Criteria Manual*. Prepared for the Denver Regional Council of Governments. Urban Drainage and Flood Control District. Denver, CO

ST-