

City of Aspen and Pitkin County
EFFICIENT BUILDING ORDINANCE

ADMINISTRATIVE AND INTERPRETIVE REGULATIONS

1.0 ADMINISTRATION

The purpose of these regulations is to set forth the procedures and requirements for the administration and implementation of the Efficient Building ordinance. These regulations are not intended to limit the administrative discretion of the persons implementing the Efficient Building ordinance on subjects not covered herein.

Note: These regulations were adopted by the Pitkin County Commissioners on April 4, 2003 and the Aspen City Council on March 15, 2003.

The intent of the City of Aspen / Pitkin County Efficient Building Program (EB Program) is to encourage cost-effective and sustainable building methods to conserve fossil fuels, water, and other natural resources, to promote the reuse and recycling of building materials and reduce solid waste, and to promote enhanced indoor air quality in residential buildings.

1.1 Point requirements

The provisions of this code shall apply to one and two family dwellings and multiple family dwellings (townhouses) not more than 3 stories in height. Such dwellings are required to earn points according to the following schedule: (Square footage is as defined by the currently adopted building codes.)

Project Description	Points Required	Thresholds
New construction	50 points	Up to 1,500 sq. ft.
New construction	65 points	Between 1,501 and 2,500 sq. ft.
New construction, each additional 50 sq. ft.	1 point	2,501 sq. ft. or greater
Interior remodel	25 points	500 – 1,000 sq. ft.
Interior remodel	35 points	1,001 - 2,000 sq. ft.
Interior remodel	45 points	2,001 sq. ft. or greater
Additions	25 points	500 – 1,000 sq. ft.
Additions	50 points	Between 1,001 and 2,500 sq. ft.
Additions, each additional 50 sq. ft.	1 point	2,501 sq. ft. or greater
Detached garages	Zero points	Up to 500 sq.ft.
Detached garages	15 points	501-750 sq.ft.
Detached garages, each 25 additional sq.ft.	1 point	Over 750 sq.ft.

For measures where a graduated point scale is used, the following shall apply:

Quantity Level 1 = 10%-25%, **Quantity Level 2** = 26%-50%, **Quantity Level 3** = 51%-75%, and **Quantity Level 4** = 76%-100%.

1.2 Inspection and compliance

These regulations identify the specific requirements for complying with the EB program. The sections and numbers in these regulations correspond to the sections and numbers on the EB Checklist. A completed EB Checklist must be submitted with the appropriate building permit application. Permit applications will not be processed unless a completed hard copy of the EB Checklist is included in the application packet. The checklist and other related documents are available at the Community Development Department; 130 S. Galena St. Aspen, CO 81611 or at www.aspenpitkin.com (see Community Development section).

Compliance with each measure described below will be demonstrated by one of two methods. If compliance is "Inspected", City staff will inspect these measures during their typical inspections, and shall require the submission of appropriate documentation to establish compliance. Inspections are listed as **PC**: Plan Check, **1**: Foundation, **2**: Framing, **3**: Insulation, **4**: Rough-in, **5**: Final. (Please read the "Compliance" section of the specific measure to see which type of inspection is required). All materials marked off on the checklist classified as "Inspected", must be identified on the plans. If a measure is indicated as "Self-Certified", the applicant's signature on the EB Checklist serves as certification that a measure will be complied with as described in each section. The City of Aspen / Pitkin County reserves the right to conduct follow-up inspections or compliance audits of self-certified measures prior to issuing a C.O. If a compliance audit is conducted, the contractor must provide documentation for these items. If for any reason an inspection fails and the checklist has to be revised for compliance, then a revised EB Checklist must be resubmitted to the building department within 30 days of the failed inspection.

1.3 Mandatory measures

Some measures in the EB Program are required for all projects. Measures identified with shading (i.e. **2.1**) indicate mandatory compliance (*required*) for all projects. Measures identified with a dark outline (i.e. **2.1**) indicate mandatory compliance (*required*) for all publicly-funded affordable housing (PFAH) projects.

1.4 Total required point calculations

NOTE: Refer to Point requirement schedule on page 1 of this document.

Example 1:

To calculate the required points for a 7500 sq. ft. *new construction* project:

The first 2500 sq.ft. requires 65 points.

In addition, every sq.ft. over 2500, requires 1 point for every 50 sq.ft.

$(7500-2500) = 5000$ divided by 50 = 100 points.

Total points required = 65 + 100 = **165**

Example 2:

To calculate the required points for a 2500 sq.ft. *remodel* and 5000 sq.ft. *addition*:

A *remodel* with more than 2001 sq.ft. requires 45 points.

The first 2500 sq.ft. of the *addition* requires 25 points;

In addition, every sq.ft. for the *addition* over 2500 sq.ft., requires 1 point for every 50

sq.ft. = (5000-2500) = 2500 divided by 50 = 50.

Total points required = 45 + 25 + 50 = **120**

For multi-family projects, *each unit* must have its own checklist for compliance. Each unit may receive credit for common items such as landscaping.

2.0 CONSTRUCTION/DEMOLITION AND CONSTRUCTION DEBRIS RECYCLING

2.1 Deconstruction Plan submitted with permit application **3 points**

(additions, remodels, or scrape-offs only)

A completed EB Deconstruction Plan is required. The Plan can be used to create a site-specific program to reduce demolition waste. Deconstructing the building to allow for the reuse of valuable building materials is encouraged but not required.

The plan requires a description of the materials to be recovered, designation of a “deconstruction contact”, site plan for collection bins, and destination of all materials expected to be recycled, reused, or resold. A significant goal is that **60% of the material** be made available for reuse.

Compliance: Inspected (**PC**): Plan Check. Completed Deconstruction Plan must be submitted to the Community Development Department, a minimum of 45 days prior to receiving a demolition permit or building permit (whichever is obtained first). During the 45-day period, the project’s “deconstruction contact”, provided by the contractor, shall be available to discuss material recovery by interested parties prior to receiving building permit.

2.2 Demolition debris reduced *(4 points required for all remodels/scrap-offs)* **4-37 points**

Compostable and/or recyclable material must be sorted for composting and/or recycling or processed for compaction. Applicants choosing 2.26 can also earn points for items 2.2.1 thru 2.2.5.

- | | |
|--|--------------------|
| 2.2.1 Wood recycled/composted (<i>= 75% of all wood</i>) | 3 points |
| 2.2.2 Metal recycled (<i>= 90% of all metals</i>) | 3 points |
| 2.2.3 Concrete recycled (<i>= 75% of all concrete</i>) | 3 points |
| 2.2.4 Carpet pad recycled (<i>= 90% of all carpet pad</i>) | 2 points |
| 2.2.5 Compaction – Grinding, shredding, crushing, etc. | 2 points |
| 2.2.6 Material salvaged for reuse (6 points per level) | 6-24 points |

Compliance: Inspected (**1**: Foundation). Present receipt from entity and place into permit sleeve.

2.3 Deconstruction materials donated to a non-profit organization **3 points**

Non-profits such as Resource 2000, Habitat for Humanity (via Construction Junction) and others will take deconstructed materials for reuse or resale, keeping the materials out of the waste stream while benefiting the community. Pitkin County Landfill will provide services for deconstructed materials as well.

Compliance: Self-certified (**S**). Present receipt from entity and place into permit sleeve.

2.4 Construction debris recycled **4-10 points**

(4 points required of all new & PFAH construction projects)

Recycle two or more of the following scrap materials from the construction of a new project:

- | | |
|---|-------------------|
| 2.4.1 Wood scrap recycled/composted (<i>1 point per Quantity Level</i>) | 1-4 points |
| 2.4.2 Metal scrap recycled (<i>= 90%</i>) | 2 points |
| 2.4.3 Cardboard recycled (<i>1 point per Quantity Level</i>) | 1-4 points |

Compliance: Self-certified (**S**).

USE OF RESOURCE EFFICIENT MATERIAL *(Part II of section 2.0)*

- 2.5 Reclaimed lumber** **5-20 points**
(5 points per Quantity Level)
Install reclaimed lumber for 10-100% of lumber. Reclaimed lumber is the re-use of already harvested lumber. Lumber is recovered from old buildings as they are torn down or from logs that have been sitting at the bottom of rivers, lakes, and streams. These timbers are often re-milled, providing a stable, trouble-free, solid building material. Points can be awarded for reclaimed timber frames.
Compliance: Self-certified (S).
- 2.6 Reclaimed exterior trim / siding / interior trim / flooring** **5-20 points** **(5**
points per Quantity Level)
Install reclaimed materials for 10 to 100% of all trim, siding and flooring areas .
Compliance: Self-certified (S).
- 2.7 Recycled-content carpeting** **1-4 points**
(1 point per Quantity Level)
Install recycled content carpeting and carpet pad in 10% - 100% of all carpeted area.
Compliance: Self-certified (S).
- 2.8 Recycled-content decking materials** **1-4 points**
(1 point per Quantity Level)
Install recycled-content decking on 10% - 100% of all decks.
Compliance: Self-certified (S).
- 2.9 Recycled-content sheathing** **1-4 points**
(1 point per Quantity Level)
Install recycled-content sheathing on 10% - 100% of all exterior walls.
Compliance: Self-certified (S).
- 2.10 Recycled-content or fiber cement siding** **1-4 points**
(1 point per Quantity Level)
Install recycled-content or fiber cement siding on 10% - 100% of all exterior walls.
Compliance: Self-certified (S).
- 2.11 Recycled-content ceramic tile** **1-4 points**
(1 point per Quantity Level)
Install recycled-content tile in 10% - 100% of all tiled area.
Compliance: Self-certified (S).
- 2.12 Recycled-content roofing** **1-4 points**
(1 point per Quantity Level)
Install recycled-content roofing on 10 - 100% of roof. Approved roofing materials include non-combustible tiles made of recycled wood fiber and concrete, recycled plastic panels, and recycled aluminum. Steel

roofing with at least 75% recycled steel content is also permitted. All roofing materials must be hail-rated for Colorado.

Compliance: Self-certified (S).

2.13 Rapidly renewable content flooring **2-8 points**
(2 points per Quantity Level)

Install rapidly renewable flooring for 10 -100% of all flooring. Rapidly renewable content materials include, but are not limited to: wool carpet, bamboo, sisal, linoleum, or cork.

Compliance: Self-certified (S).

2.14 Built in kitchen recycling center to include 2 or more bins **2 points**

Install an indoor recycling center containing 2 or more bins in the kitchen area.

Compliance: Self-certified (S). Recycling center must be identified on plans.

3.0 LAND USE AND WATER CONSERVATION

3.1 Keep footprint simple **1-3 points**

Reduce waste and improve energy efficiency with a simple footprint as follows for:

3.1.1 = 4 corners *(no points for 3.1.2 or 3.1.3)* **3 points**

3.1.2 = 6 corners *(no points for 3.1.1 or 3.1.3)* **2 points**

3.1.3 = 8 corners *(no pts for 3.1.1 or 3.1.2)* **1 point**

For this program, corners refer to any corner included of the thermal envelope that is 50% or more of the average wall height.

Compliance: Inspected (1: Foundation). Verification of footprint approved at plan review.

3.2 Xeriscape Landscaping *(2 points required of PFAH projects)* **1-5 points**
(1 point for each measure)

Applicants can earn points by selecting xeriscape measures.

3.2.1 Addition of organic material to and aeration of soil. Organic material can include, but is not limited to, manure and compost.

3.2.2 Reduction of turf areas. No more than 25% of landscaped area or 3000 square feet (which ever is smaller) can be covered with high water demand turf, such as Kentucky bluegrass. For the Aspen/Pitkin County climate more appropriate turf can include, native, low water, bunch grasses for fringe areas.

3.2.3 All planting beds mulched with wood chips at least 2" deep. (Except desert plantings.)

3.2.4 Appropriate use of low-water-demand plants. All plants to be grouped by water needs. 75% of the landscape must use low or moderate water demand plants.

3.2.5 Zoned irrigation system. Irrigation system must be zoned to deliver different amounts of water appropriate to the different plant zones. High-water zones should have irrigation controls that include timed devices and be surrounded on 75% of the perimeter with other water zones; no high-water zones should be immediately adjacent to large hardscapes such as driveways or streets, and for efficient irrigation, high water zones should not be installed in areas less than 15 feet wide. The remainder of the landscape should include low to moderate water demanding plants, and should be irrigated with drip irrigation, bubbler, or micro-spray systems.

Compliance: Self-Certified (S).

3.3 Water conservation by performance method **1-13 points**

(2 points required of PFAH projects)

Showers and faucets: Points are available for accumulated water savings over code for listed fixtures and/or for dual flush toilets, composting toilets and/or single showerheads.

3.3.1 One point is earned for every one gallon per minute savings over code.

CODE: Showerhead = 2.5 gpm; Toilet = 1.6 gpm; Lav.faucet = 2.2 gpm; Kit. faucet = 2.2 gpm

3.3.2 Dual flush toilet *(1 point each, no credit for toilet in 3.3.1)* **1-4 points**

3.3.3 Composting toilet *(2 points each, no credit for toilet in 3.3.1)* **2-8 points**

3.3.4 Only one showerhead in all showers **1 point**

Compliance: Inspected (5: Final).

3.4 No irrigation system or install a drip irrigation **5 points**

Do not install a permanent irrigation system or install drip irrigation system for these points.

Compliance: Inspected (5: Final).

3.5 Engineered/vegetated swales to filter storm water runoff **1-4 points**
(1 point per Quantity Level)

Submit a diagram showing water drainage patterns (paths) from developed areas and a watercourse to vegetated swales. Water from developed areas should be diverted to vegetated swales to slow and filter storm water egress flow prior to leaving the site. For city projects, an engineered site drainage plan is required by code.

Compliance: Inspected (5: Final).

3.6 Planting trees above requirements **1-10 points**

Applicant receives 1 point for each additional tree (beyond code requirements). Tree planting points are limited to a maximum of 10 total points (ten trees).

Compliance: Inspected (5: Final).

3.7 Save and reuse all topsoil and/or excavated fill on site **3-8 points**

3.7.1 Topsoil from the site must be reused on site **3 points.**

3.7.2 Use 100% of excavated fill on-site **5 points.**

Topsoil must remain on site during construction. Storage area for topsoil must be indicated on the site plan.

Compliance: Inspected (1: Foundation).

3.8 Site-rock reclaimed on site **2-8 Points**
(2 points per Quantity Level)

Reclaim 10-100% of site rock on site. Rock must remain on site during construction. Storage area for rock must be indicated on the site plan. Site rock is used for rock applications i.e. retaining walls, landscaping, veneer applications, etc.

Compliance: Self certified (S). Place letter from entity in permit sleeve.

3.9 Non-potable water used for irrigation **4 points**

Use systems, such as rainwater catchments, to save and store water on-site for use as irrigation or use ditch water if available. Verify compliance with local and state regulations prior to construction.

Compliance: Self-certified (S).

**3.10 Pervious materials in “hardscape” areas.
(2 points per level)**

2-8 points

Construct 10-100% of “hardscape” areas (walkways, patios and driveways) with pervious materials.

Compliance: Self-certified (**S**).

4.0

FRAMING & MATERIALS

4.1 Incorporate optimal value engineering (OVE) framing techniques

(6 points required of PFAH projects)

2-42 points

Use advanced framing techniques in design specifications and construction. Optimum value engineering (OVE) framing techniques include:

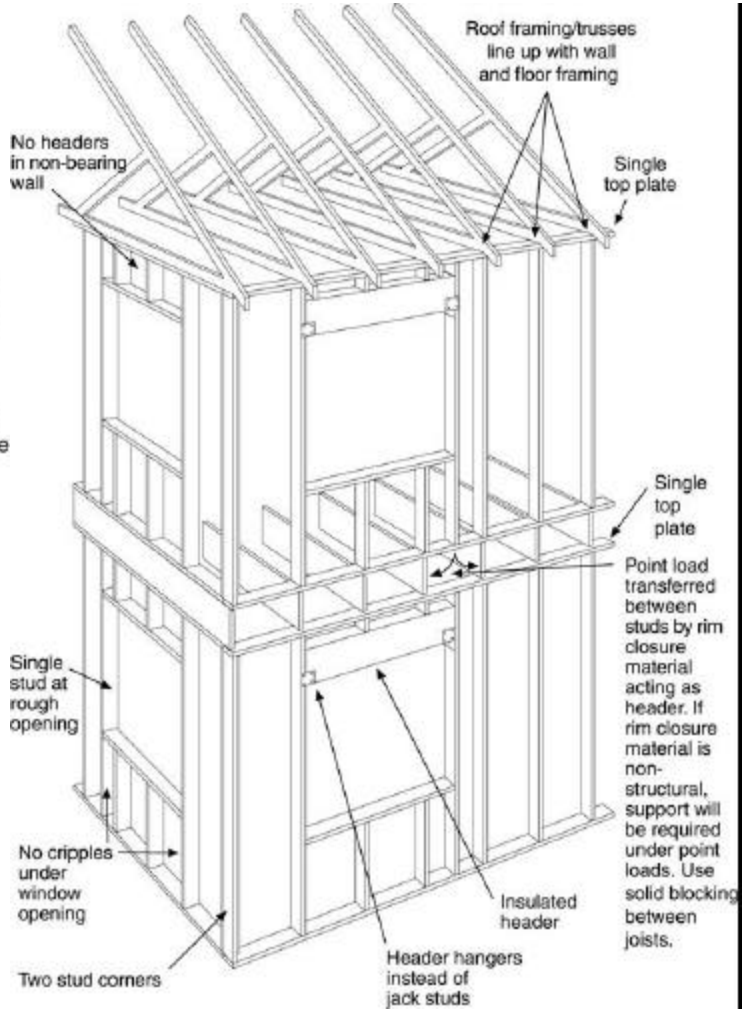
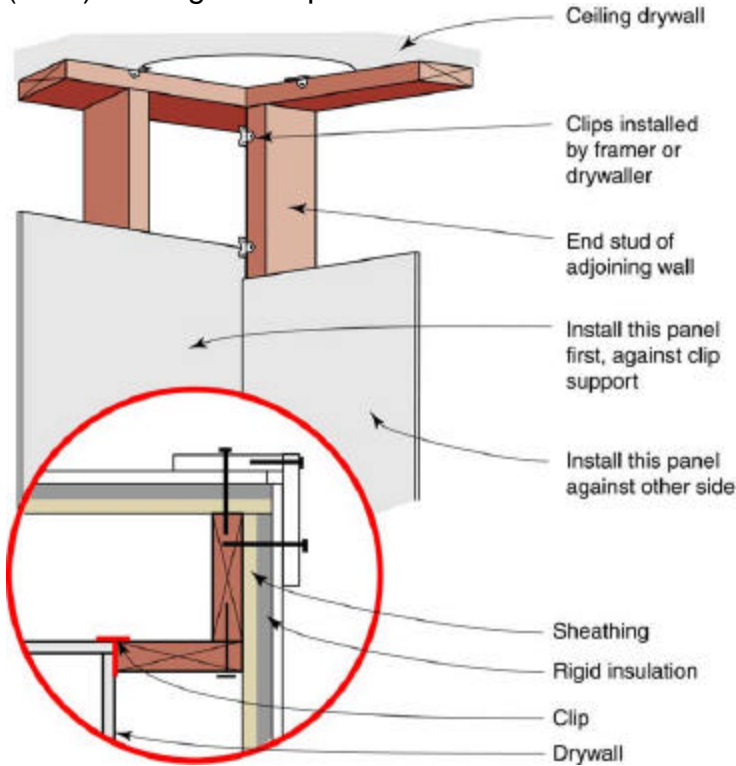

These details taken from *Builder's Guide – Cold Climates*; courtesy of Building America, Energy and Environmental Builders Association and Building Science Corporation. They are intended to serve as examples only for measure 4.1. This book is available at www.eeba.org.

- 4.1.1 24" o.c. studs** (3 points per Quantity Level for all framing) **3-12 points**
- 4.1.2 Two stud corners** (2 pts per Quantity Level for all framing) **2-8 points**
- 4.1.3 Efficient headers** (2 pts per Quantity Level for all framing) **2-8 points**
Efficient headers refers to insulated headers on exterior walls (min. R-10) or eliminating headers in non-load bearing walls.
- 4.1.4 Stacking joists over studs with single top plates** **2-8 points**
(2 points per level for all framing)
- 4.1.5 Build with two-foot increments** (= 75% of footprint) **3 points**
- 4.1.6 All framing members shown on drawings in plan and elevation.** **3 points**

Compliance: Inspected (2: Framing).

- 4.2 Oriented Strand Board (OSB) in subfloors** **1-4 points**
(1 point per Quantity Level)
 Sub floors (10-100%) constructed with Oriented Strand Board (OSB).
Compliance: Inspected (**2:** Framing).
- 4.3 Oriented Strand Board in wall sheathing** **1-4 points**
(1 point per Quantity Level)
 Use Oriented Strand Board for 10% - 100% of exterior wall sheathing applications.
Compliance: Inspected (**2:** Framing).
- 4.4 Low-toxic OSB** **2-8 points**
(2 points per Quantity Level)
 Use low-toxic OSB for 10 –100% of OSB wherever OSB is specified. GREENGUARD™ Certified OSB complies with this requirement.
Compliance: Inspected (**2:** Framing).
- 4.5 Finger-jointed studs or engineered studs for wall framing** **2-8 points**
(2 points per Quantity Level)
 Use finger-jointed studs or engineered studs for 10% - 100% of all framing.
Compliance: Inspected (**2:** Framing).
- 4.6 Finger-jointed interior trim** **1-4 points**
(1 point per Quantity Level)
 Use finger-jointed trim for 10% - 100% of all interior trim.
Compliance: Self-certified (**S**).
- 4.7 FSC® certified materials:** **2-88 points**
- 4.8.1 FSC® certified sustainably harvested lumber** **4-16 points**
(4 points per Quantity Level for all exterior walls)
 Use FSC® certified sustainably harvested lumber for 10% -100% of all exterior walls.
Compliance: Inspected (**2:** Framing). FSC® certification placed in permit sleeve.
- 4.8.2 FSC® cedar shakes** *(4 points per Quantity Level for all roofing)* **4-16 points**
- 4.8.3 FSC® trim & flooring** *(4 pts per Quantity Level for all trim & flooring)* **4-16 points**
- 4.8.4 FSC® cabinets** *(4 points per Quantity Level for all cabinets)* **4-16 points**
- 4.8.5 FSC® doors/windows** *(4 pts per Quantity Level for all doors and/or windows)* **4-16 points**
- 4.8.6 Outdoor structures, decking and landscaping forms made with dimensional FSC® lumber** *(2 points per Quantity Level for all exterior structures)* **2-8 points**
- Compliance:** Inspected (**5:** Final). FSC® certification placed in permit sleeve.
- 4.8 SFI™ certified materials:** **2-68 points**
- 4.8.1 SFI™ certified sustainably harvested lumber** **3-12 points**
(3 points per Quantity Level for all exterior walls)
 Use SFI™ certified sustainably harvested lumber for 10% -100% of all exterior walls.

Compliance: Inspected (2: Framing). SFI™ certification placed in permit sleeve.

4.8.2 SFI™ cedar shakes (3 points per Quantity Level for all roofing) **3-12 points**

4.8.3 SFI™ trim & flooring (3 pts per Quantity Level for all trim & flooring)
3-12 points

4.8.4 SFI™ cabinets (3 points per Quantity Level for all cabinets) **3-12 points**

4.8.5 SFI™ doors/windows (3 pts per Quantity Level for all doors and/or windows)
3-12 points

4.8.6 Outdoor structures, decking and landscaping forms made with dimensional SFI™ lumber (2 points per Quantity Level for all exterior structures)
2-8 points

Compliance: Inspected (5: Final). SFI™ certification placed in permit sleeve.

4.9 Engineered lumber used in floors and roofs (3 points required of PFAH projects)
(1 point per Quantity Level for floor & roof framing) 1-4 points

Install engineered lumber in framing. Engineered lumber includes, but not limited to: wood “I” joists, engineered trusses, or other remanufactured wood fiber structural materials.

Compliance: Inspected (2: Framing). Engineered material must be specified on structural plans.

4.10 Engineered lumber used to replace 2x10s or 2x12s for structural bearing applications
2 points

Replace = 75% of all 2x10’s and/or 2x12’s with engineered lumber. Products include, but are not limited to: gluelam, microlam, laminated veneer lumber, and parallel strand lumber.

Compliance: Inspected (2: Framing). Engineered material must be specified on structural plans.

4.11 Structural alternatives to wood-frame construction **5-20 points**
(5 points per Quantity Level for exterior walls)

Construct 10-100% of exterior walls with alternative materials, which may include, but is not limited to: adobe, rammed earth, and straw bale.

Compliance: Inspected (2: Framing). Applicant must provide plans or designs certified by a structural engineer and in compliance with the requirements of the City of Aspen/Pitkin County.

4.12 Structural Insulated Panels (SIP’s) for exterior walls and/or roofs **2-8 points**
(2 points per Quantity Level for non-foundation building envelope)

Structural insulated panels (SIP) used for exterior walls and/or roof.

Compliance: Inspected (2: Framing).

4.13 Factory built or panelized homes **1-4 points**
(1 point per Quantity Level of exterior wall)

Factory built or panelized construction used for exterior walls and/or roof. Resource-efficient techniques must be used in off-site construction.

Compliance: Inspected (2: Framing). Provide manufacturers’ specifications outlining resource efficient techniques for plan review.

4.14 Recycled-content Insulated Concrete Forms (ICF’s) **2 points**
(= 75% of all ICF’s)

Install insulated concrete forms with recycled-content such as post-consumer plastic or fly ash for foundation walls.

Compliance: Inspected (1: Foundation).

4.15 Insulated Concrete Forms (ICF's)

1-4 points

(1 point per Quantity Level for foundation walls)

Install insulated concrete forms for 10% - 100% of foundation walls.

Compliance: Inspected (1: Foundation).

4.16 Non-solvent based foundation waterproofing

2 points

Use non-solvent based damproofing on all walls receiving damproofing.

Compliance: Self-certified (S).

4.17 Frost-protected shallow foundation

3-12 points

(3 points per Quantity Level)

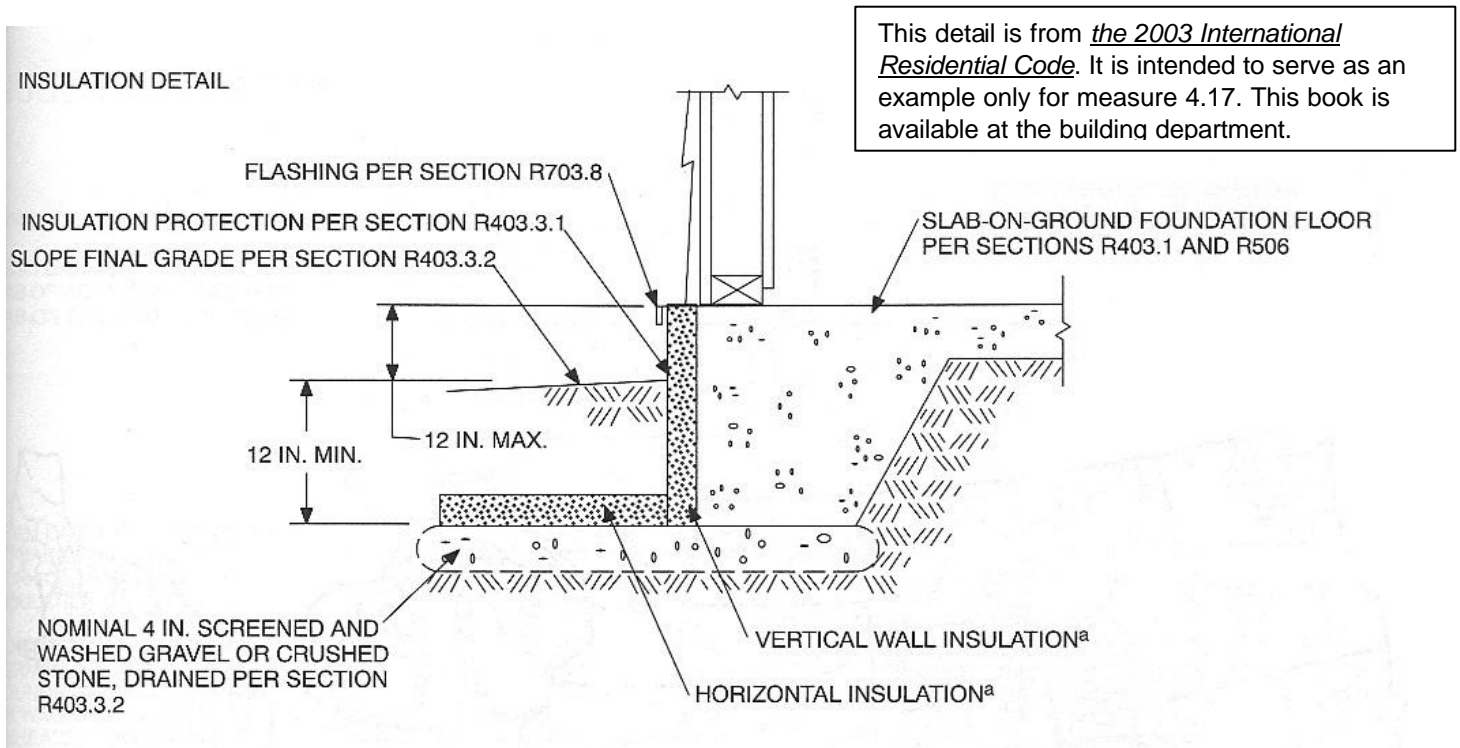

Use this design technology for 10% -100% of foundation. Provide details as per the 2003 International Residential Code.

Compliance: Inspected (1: Foundation).

4.18 Twenty percent fly ash content in all structural concrete

1-4 points

(1 point per Quantity Level of all structural concrete)

Specify 20% fly ash content in 10% -100% of structural concrete.

Compliance: Inspected (1: Foundation). Batch report for fly ash content in permit sleeve.

5.0

ENERGY CODE MEASURES

5.1 Performance exceeding the Aspen/Pitkin County Energy Code 1-10 points

(4 points required of PFAH projects)

One point is awarded for every 5 % performance over “Pass” according to MEC check energy calculations. For example: For 10% better than code performance, 2 points are earned. No points can be earned if a snowmelt system and/or a heated pool or spa is incorporated into the project.

Compliance: Inspected (**PC:** Plan Check).

5.2 Window quilts or insulated window shades 1 point **(= 50% of all windows)**

Install insulated window shades or window quilts on = 50% of the windows.

Compliance: Self-certified (**S**).

5.3 Mechanical equipment centrally located 1 point

Locate mechanical equipment within the middle third (1/3) of the distance of the longest horizontal diagonal.

Compliance: Inspected (**PC:** Plan Check).

5.4 Energy Star® House (5 Star Rating) 5 points

Obtain a ‘Final’ rating certificate for the house by Energy Rated Homes of Colorado (E-Star™), with a score of at least 86. An E-Star™ ‘From-Plans’ rating certificate can be used with a building permit application as per APECC compliance, provided there is no outdoor spa, pool and/or snowmelt.

Compliance: Inspected (**5:** Final). E-Star™ ‘Final’ rating certificate placed in permit sleeve

5.5. Energy 10 Analysis 3 points

Use Energy 10 computer software to analyze the building’s energy performance. Energy 10 cannot be used for APECC compliance; i.e. Calres applications.

Compliance: Inspected (**PC:** Plan Check).

5.6 All ductwork sealed with mastic 1 point

Use mastic to seal all duct work; duct tape is not allowed.

Compliance: Inspected (**4:** Rough-in).

5.7 Insulate all hot water pipes 1 point

Insulate all hot water pipes with R-2.5 to all locations.

Compliance: Inspected (**4:** Rough-in).

5.8 Unvented crawlspace

3 points

Construct all crawlspaces according to guidelines in ASHRAE Book of Fundamentals, section 23.11.

Provide details demonstrating an approved design.

Compliance: Inspected (3: Insulation).

5.9 Side-arm hot water heater

2 points

Install a side-arm or indirect heat coil from the boiler for domestic hot water.

Compliance: Inspected (5: Final).

5.10 Energy efficient boiler or furnace

5-10 points

Install a minimum 87% efficient boiler or modulating boilers or sequentially staged boilers for efficient operation when demand is less than full heat load. For a forced-air system, install a 94% efficient furnace.

5.10.1 87% (min.) efficient boiler or 94% (min.) efficient furnace

5 points

5.10.2 Modulating or sequentially-staged boilers

5 points

Compliance: Inspected (5: Final). Equipment must be specified in the energy calculations.

5.11 Outdoor reset thermostat control

3 points

Install an outdoor reset thermostat to measure both outdoor air temperature and heating system supply temperature. The reset thermostat shall regulate heating supply water temperature for a more efficient heating system.

Compliance: Inspected (5: Final).

5.12 High efficiency gas hot water heater

4 points

Install a high efficiency (= 88%) gas hot water heater. (Stand-alone units only.)

Compliance: Inspected (5: Final).

5.12 Manual J calculations used for sizing mechanical equipment

3 points

Compliance: Inspected (PC: Plan Check). Submit calculations with checklist.

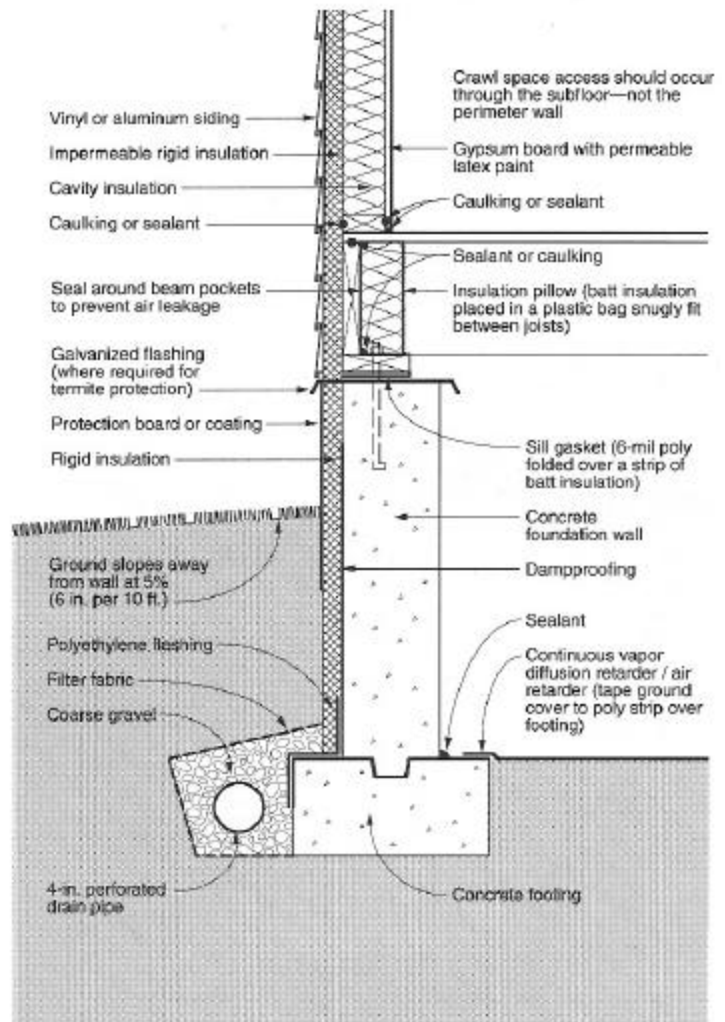

Figure 5-14: Crawlspace 1—mixed climate.

This detail is from *Moisture Control Handbook* by Joe Lstiburek and John Carmody. It is intended to serve as an example only for measure 5.8. This book is available at www.eeba.org ..

6.0

PLUMBING

6.1 Tankless water heater

2 points

Install a tankless hot water heater. The device must have a variable-set thermostat and be sized to Manual J specifications.

Compliance: Inspected (5: Final).

6.2 "On-Demand" hot water switch

3 points

Install an "on-demand" circulation device (pump) to circulate domestic hot water from the hot water heater to the furthest fixture away from the water heater through a separate recirculating line. An automatic push button activated device with internal aquastat may be utilized with a separate recirculating line to carry the "warm" water back to the water heater. The designated recirculation loop should be supplied with a check valve to insure proper water flow. An ON/OFF switch should be supplied for aquastat type controls so they may be deactivated during unoccupied times when not needed. Constant circulation systems are not acceptable for this measure.

Compliance: Inspected (5: Final).

7.0

ELECTRICAL

7.1 Energy Star[®] rated appliances (2 points required of PFAH projects) **1-10 points** (1 point for each appliance)

Install an energy efficient dishwasher, clothes washer, refrigerator and/or freezer. "Energy Efficient" appliance designation is indicated on the required Department of Energy "Energy Star[®]" label. Appliances shall be selected from the most efficient category in the top quarter of the Energy Star[®] list.

Compliance: Inspected (5: Final).

7.2 Clothesline

1 point

Install a permanent clothesline inside or outside.

Compliance: Self-certified (S).

7.3 Energy efficient clothes washers

3 points

Select a horizontal axis washer referenced in the Resource Guide for an extra point over the Energy Star[®] washer.

Compliance: Inspected (5: Final).

7.4 Compact Fluorescent (CFL) bulbs (1 point required of PFAH projects) **1-10 points**

One point will be awarded for every four bulbs/lamps, up to a maximum of 10 points (points may be awarded for additions or existing square footage as well as new construction). T8 & T5 fluorescent bulbs also qualify.

Compliance: Inspected (5: Final).

7.5 Efficient light controls

2 points

Control at least 2 interior spaces with efficient lighting controls. Efficient lighting controls include occupancy/motion sensors and automatic daylight dimming controls.

Compliance: Inspected (5: Final).

8.0 INSULATION

8.1 Wall insulation is 70% recycled material (= 75% of thermal envelope) 2 points

Install insulation with at least 70% recycled content material in exterior walls. This includes, but is not limited to Insulation made from recycled - newsprint, wood fiber, agricultural waste, cotton or mineral wool.

Compliance: Inspected (3: Insulation). Insulation certificate placed in permit sleeve.

8.2 Roof insulation is 70% recycled material (= 75% of thermal envelope) 2 points

Install insulation with at least 70 % recycled content material in roof/attic. Insulation made from recycled materials: newsprint, wood fiber, agricultural waste, cotton or mineral wool can be used.

Compliance: Inspected (3: Insulation). Insulation certificate placed in permit sleeve.

8.3 Blown / sprayed insulation (= 75% of thermal envelope) 4 points

Install blown / sprayed insulation in walls and/or roofs/attics. Points are also awarded for sections 8.1, 8.2 and/or 8.3.

Compliance: Inspected (3: Insulation). Insulation certificate placed in permit sleeve.

8.4 Formaldehyde-free and/or low toxic Insulation (= 75% of thermal envelope) 2 points

Install formaldehyde-free and/or insulation in wall and/or roofs/attics. Points are also awarded for sections 8.1, 8.2 and/or 8.3. GREENGUARD™ Certified insulation complies with this requirement.

Compliance: Inspected (3: Insulation). Insulation certificate placed in permit sleeve.

8.5 Single-pane windows upgraded (*additions/remodels only*) 1-10 points

Applicant must replace single-pane windows with double-glazed windows according to the following schedule: (Points are awarded for one category only.)

8.5.1 Double-glazed (max U-value= 0.40) .5 point per window

8.5.2 Double-glazed with low-e coating (max U-value = 0.35) 1 point per window

8.5.3 Spectrally selective film applied to historic windows .5 point per window

Compliance: Inspected (5: Final). The inspector must be able to clearly identify the U-value and window type by either the National Fenestration Rating Council's sticker or the Manufacturer's label.

8.6 Existing ceiling/roof insulated to R-38 or to capacity (*additions/remodels only*) 7 points

Increase ceiling/roof insulation in existing structure to R-38, where possible, which is generally intended to be in ceilings below attic space, with appropriate gable or soffit ventilation.

NOTE: If existing cathedral or flat ceilings are already insulated, it is not recommended to install more insulation in the cavity. Refer to the building code for ventilation requirements.

Compliance: Inspected (3: Insulation). An insulation certificate dated on or after the date of the building permit issuance must be placed in permit sleeve.

8.7 Existing walls insulated to capacity or rigid insulation added to exterior

(additions/remodels only)

5 points

Insulate walls of existing wood frame houses to capacity. The existing home qualifies only if the walls have no existing insulation or if the insulation has settled or degraded. Wall cavities with existing insulation can be blown full of new cellulose or fiberglass to increase the density, thereby increasing the R-value. Exterior walls can be wrapped with a minimum of 1" (R-4) rigid foam to increase R-value; two inches is recommended.

Compliance: Inspected (3: Insulation). An insulation certificate dated on or after the date of the building permit issuance must be placed in permit sleeve.

9.0 HEATING, VENTILATING, AND AIR CONDITIONING (HVAC)

9.1 Air destratification system

1 point

Design and install a system to reduce the stratification of warm air in residential living spaces. The systems are to be used on ceilings greater than 10 feet in height, or in stairwells. The systems can include: blade-type ceiling fans, heat siphon fan units, return ducting mounted at the high point of ceilings, calculated air flow pathways, utilizing high- and low placed operable windows/vents in passive solar systems, or other proven, documented systems designed to reduce stratification.

Compliance: Inspected (5: Final).

9.2 Natural cooling *(1 point required of PFAH projects)*

1- 5 points

One point will be awarded for natural cooling systems for each measure described below:

9.2.1 Vertical shading devices for = 75% of east and west-facing glass.

9.2.2 Reflective films on = 90% of east and west-facing glass or use windows with a Solar Heat Gain Coefficient of less than 0.45.

9.2.3 Radiant heat-reflective barriers installed on = 90% of roof applications.

9.2.4 Landscaping that shades = 75% of east and west facing glazing during the summer season (June-August).

9.2.5 Properly sized overhangs for = 75% of south facing (within 30°) glazing area. The formula below will result in window overhangs that shade 100% of south-facing window glazing on June 21st (the summer solstice).

F=3.38 Applicants should use this formula as a guide for sizing all south-facing overhangs.

D=H/F where:

D = Distance of overhang from face of glass

H = Height from bottom of glass to bottom of overhang

F = 3.38 (F is a value corresponding to the noon sun altitude angle on June 21st, which results in 100% window shading).

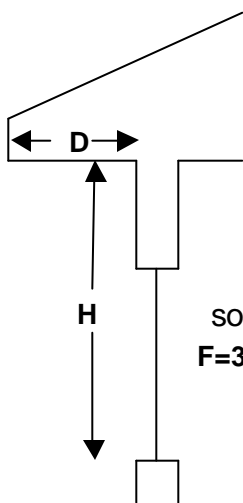

Compliance: Inspected (5: Final). For option 9.2.5 applicant must submit a calculation for "D" that demonstrates overhangs have been designed in accordance with the equation above for all south-facing glazing.

9.3 No mechanical air conditioning

5 points

Do not install compressed refrigerant systems for temperature control.

Compliance: Inspected (5: Final).

9.4 Evaporative cooling

1 point

Install an evaporative cooling system instead of a compressed refrigerant air conditioner. No points allowed for Section 9.3 above.

Compliance: Inspected (5: Final).

9.5 Air infiltration rate below specified levels

4-14 points

(4 points required of PFAH projects)

Applicant must provide blower door test results identifying the Natural Air Change per Hour (NACH) rate for the house. Points are awarded for meeting the following air infiltration rates:

9.5.1 0.40 NACH

4 points

9.5.2 = 0.35 NACH (2 additional pts for every .05 NACH reduction)

6-14 points

Note: To earn points for air infiltration rates less than or equal to .35 NACH, mechanical ventilation that allows a minimum of .35 NACH must also be installed and inspected.

Compliance: Inspected (5: Final). Place blower door test result in permit sleeve. (Note: A blower door test is included in an E-Star™ rating.)

9.6 Whole-House Fan

2 points

Install a whole-house fan with an insulated cover. The fan must be mounted in a common area ceiling on the top floor of the house. The fan must have two speeds: low speed for continuous ventilation and high speed to vent the entire house quickly. Insulation, louvered vents, and an airtight seal are required to prevent air infiltration or exfiltration. Fans should be sized to produce between 4-5 air changes per hour at top speed within the home. Fans are rated in terms of the number of cubic feet per minute (CFM) of air they move. For design purposes, to determine the appropriate size fan for your project, use the following formula:

Minimal Fan Size (CFM)= Volume of House x 4-5 air changes/hour x 1/60

Volume of House= square footage of house x average ceiling height throughout house

Compliance: Inspected (5: Final).

9.7 Convert electric resistance heat to gas (additions/remodels only)

10 points

Replace an existing whole house electric resistance heating system with a natural gas heating system sized to accommodate the heating load of the entire house.

Compliance: Inspected (5: Final). Applicant must provide documentation that conversion occurred on or after the date of building permit issuance.

9.8 Replace electric water heater with a gas water heater (additions/remodels only)

4 points

Replace an electric hot water heater with a gas water heater sized to accommodate the water-heating load.

Compliance: Inspected (5: Final). Applicant must provide documentation that conversion occurred on or after the date of building permit issuance.

9.9 Hydronic heat

3 points

Install a system that distributes hot water heat in the floor or by radiators to two or more zones. No points can be awarded if points are taken for Section 9.7.

Compliance: Inspected (5: Final)

9.10 Air to air heat exchanger (heat recovery ventilation)

8 points

Install a mechanical heat recovery ventilation system that recovers at least 60% of the heat from exhausted indoor air.

Compliance: Inspected (5: Final)

Note: Use of this equipment complies with the requirements of Section 9.5 for houses with a NACH of less than .35.

10.0

SOLAR

10.1 Passive solar space heating

10-20 Points

Points for passive solar space heating are obtained for either Sections 10.1.4 or 10.1.5. Install south facing glazing to capture solar energy and meet the prerequisites in Sections 10.1.1, 10.1.2 and 10.1.3.

10.1.1 Prerequisite South facing glazing is oriented within 30 degrees of east of true south or 30 degrees west of true south direction.

10.1.2 Prerequisite Size overhangs so that south facing glazing is not shaded between 10 a.m. and 2 p.m. on a clear winter solstice day and is totally shaded (by the eaves) between 10 a.m. and 2 p.m. on the summer solstice (see Section 9.25 for sizing calculation).

10.1.3 Prerequisite Solar access is unimpeded under easements, covenants, or other private agreements among affected landowners that the Building Official finds are adequate to protect continued solar access for south facing glazing.

10.1.4 Sun tempered

10 points

Install south facing glass equivalent to 6-7% of total heated floor area.

Compliance: Inspected (**PC:** Plan Check). Provide calculation south facing glass vs. total heated floor area on plans.

10.1.5 Passive solar

20 Points

Install south facing glass equivalent to 7-12% of total floor area. Thermal mass must be added, either in the floor or walls, for each square foot of south facing glass over 7% of the floor area.

Types of thermal mass which can be used include: concrete floors, two layers of sheetrock, exterior sheet rock, gypcrete (2 inches), tile floors, masonry, thick plaster, adobe walls, stone fireplaces, etc.

Compliance: Inspected (**PC:** Plan Check). Provide calculation of percentage of south facing glass and amount of thermal mass required with plans.

10.2 Solar heating system for domestic hot water

10 points

Install a solar system, which includes rooftop or ground-mounted panels (collectors), to collect and distribute solar heat to a heat exchanger and/ or insulated storage tank for domestic hot water supply. Systems may be active, using pumps, or they may be a thermo siphon-type.

The collectors must be mounted to achieve a minimum 85 % Orientation Adjustment Factor (refer to the Solar Table in the Resource Guide), by the combination of slope angle from the horizontal and orientation versus true south. No points can be awarded if points are taken for Sections 10.3 or 10.4.

10.2 Con't. System size is dependent on number of bedrooms. Collector size and storage tank size:

1 bedroom - 40 sq ft of solar collectors, 50 gallons storage;

2 bedrooms – 48 sq.ft. of solar collectors, 60-65 gallons storage;

3 bedrooms – 64 sq ft of solar collectors, 80 gallons storage;

4 bedrooms or more – 96 sq.ft. of solar collectors, 120 gallons of storage.

Compliance: Inspected (5: Final). Show collector panels on plans and specify panel sizes. Solar hot water systems may be installed off-site if approved by CORE Board.

10.3 Active solar pre-plumbing

2 points

The piping is to be installed in an interior wall and shall start in the mechanical room or near the area that will house the storage tank. The piping should terminate in an attic space under the roof that will support the solar collectors, and it shall be above the insulation for easy sighting. If there isn't an attic space, the piping shall end after penetrating the roof that will support the collectors. The two runs of piping shall be type M copper and be a minimum of 3/4 inch in diameter. All joints shall be soldered with lead-free solder.

The piping shall be insulated with a minimum R-6. The insulation shall run continuously without any exposed piping. Run three conductors thermostat wire from the mechanical room to the roof. No points can be earned if snowmelt and/or a heated pool or spa is incorporated into the project.

Pre-plumbed for future active solar retrofit. No points can be awarded if points are taken for Sections 10.2 or 10.4.

Compliance: Inspected (5: Final).

10.4 Active solar space heating, with solar domestic hot water

15 Points

Install a solar system, which includes rooftop or ground-mounted panels (collectors), to distribute solar heat to a heat exchanger and/ or insulated storage tank in order to meet part of the winter heating load. Area of solar collectors shall be 5-7% of total heated floor area. No more than 320 square feet of collector shall be installed on a house. The collectors for the solar system must be mounted with a minimum slope from the horizontal of 40 degrees. Also the position of the collectors must result in a minimum 90 % Orientation Adjustment Factor by the combination of slope from the horizontal and orientation versus true south. See the Solar Table in the Resource Guide.

The system shall also be used to provide domestic hot water. Solar system design shall have at least 2 gallons of storage for every square foot of collector. If the system is not a drain-back system, the solar hot water system must have a means of dissipating or using solar heat in the summer months. No points can be awarded if points are taken for Sections 10.2 or 10.3.

Compliance: Inspected (5: Final). System design shall be detailed in mechanical plans. Mounting angles specified on the plans. Solar hot water systems may be installed off-site if approved by CORE Board.

10.5 Solar-Generated Electricity

10-80 points

Install a solar-generated electric or photovoltaic system for these points. Photovoltaic panels should be mounted facing south either on a roof or on the ground, at an angle, which provides 90 % rated output as per the Orientation Adjustment Factor Table in the Resource Guide. Panels shall not be shaded between the hours 10 AM-2PM year round. Systems must be grid-tied if the electric grid is to the property line. Applicants with houses over 5000 sq.ft installing a photovoltaic system can receive a credit towards REMP fees.

10.5.1 System size of 1 KW

10 Points

10.5.2 System size of = 1.5 KW (5 additional pts for every .5 KW)

15-80 Points

Compliance: Inspected (5: Final). Applicant must submit diagrams by a qualified architect, engineer, or designer certifying the KW capacity, mounting angle meets 90% rated output of solar electric power. Solar-electric systems may be installed off-site if approved by CORE Board.

11.1 Low VOC and/or low-toxic Interior Paint *(2 points required of PFAH projects)***1-4 points****(1 point per Quantity Level)**

Paint 10% - 100% of interior walls with low or no volatile organic compound (VOC) paint containing less than 250 grams VOC/liter. GREENGUARD™ Certified paint complies with this requirement.

Compliance: Self-certified (**S**).

11.2 Solvent-free and/or low-toxic construction adhesives **1 point**

Use construction adhesives free of aromatic hydrocarbons or solvents, throughout the house. GREENGUARD™ Certified adhesives comply with this requirement.

Compliance: Self-certified (**S**).

11.3 High efficiency filter on furnace **2-5 points**

Install a high efficiency filter on a forced-air furnace system. Any HEPA filter must be rated at 99% efficiency or higher.

11.3.1 High Efficiency pleated air filter **2 points****11.3.2 High Efficiency Particulate Air (HEPA) filter** **5 points**

Compliance: Inspected (**5**: Final).

11.4 Rough-in for radon mitigation **3 points**

Install a four-inch PVC pipe under the floor (under slab or under crawlspace vapor barrier/mat) of new construction, for future evacuation of potential radon gas, as per EPA guidelines.

Compliance: Inspected (**PC**: Plan Check).

11.5 Radon mitigation **5 points**

Design and install radon mitigation system according to generally recognized practices to remove radon from under the slab and vent to a location away from pedestrian traffic areas, per EPA regulations. No points can be awarded if points are taken for Sections 11.4.

Compliance: Inspected (**PC**: Plan Check).

11.6 Solvent-free and/or low-toxic wood finishes **1-4 points****(1 point per Quantity Level)**

Finish 10 - 100% of unfinished, interior wood with solvent-free, water-based, low-toxic finishes. GREENGUARD™ Certified finishes comply with this requirement.

Compliance: Self-certified (**S**).

11.7 Low toxic floor coverings **1-4 points****(1 point per Quantity Level)**

Install chemical free carpeting, cork, linoleum or other low-toxic floor coverings for 10% - 100% of all floor coverings. GREENGUARD™ Certified products comply with this requirement.

Compliance: Self-certified (**S**).

11.8 Carbon monoxide detector **3 points**

Install an electric (hard-wired) or AC/DC carbon monoxide detector, located according to manufacturer's recommendation.

Compliance: Inspected (5: Final)

11.9 Non-atmospheric vented (sealed combustion) gas furnace/boiler & water heater **5-10 points**
(5 points for each piece of equipment)
(5 points required of PFAH projects)

Install a non-atmospheric vented (sealed combustion) gas furnace, boiler, and/or water heater.

Compliance: Inspected (5: Final).

11.10 Sealed mechanical room **2 points**

Mechanical equipment such as the furnace/boiler and water heater must be located in a separate room. The room should be sealed off with a continuous air-barrier, to minimize air infiltration from the mechanical area to the rest of the house and be insulated to R-11. Room must be fitted with an exterior solid-core door weather-stripped to exterior specifications.

Compliance: Inspected (3: Insulation).

11.11 Exhaust fan installed in attached garage or no attached garage 5 points

For attached garages, install an exhaust fan with a timer and/or sensor. Points can also be awarded if the garage is built detached from house.

Compliance: Inspected (5: Final).

11.12 Elimination of all particleboard inside envelope of house **5 points**

Do not install any formaldehyde-based particleboard inside the house.

Compliance: Self-certified (S).

11.13 Elimination of all medium density fiberboard made with urea-formaldehyde inside envelope of house **3 points**

Do not install any urea formaldehyde-based MDF inside the house.

Compliance: Self-certified (S).

11.14 All exposed particleboard sealed **2 points**

Seal all exposed particleboard, such as cabinets, counter tops, stair treads, shelving, etc. with 3 coats of low VOC, non-toxic sealer.

Compliance: Self-certified (S).

11.15 American Lung Association "Health House" **5 points**

Obtain certification through "Health House", American Lung Association standard.

Compliance: Inspected (5: Final). Provide certification.

11.16 Mechanical ventilation installed **4 points**

Provide 15 cfm per person as per ASHRAE Standards. See also Section 9.12 for alternative method for indoor air quality improvement with air-to-air heat exchanger.

Compliance: Inspected (5: Final).

12.1 Innovative product or design**1-20 points**

Provide information demonstrating exceptional performance in environmental efficiency above the measures listed in this program.

Compliance: Inspected (**PC:** Plan Check / **5:** Final). Product and/or the design must be approved by the Building Official.

12.2 Alternative fuel infrastructure**5 points**

Install infrastructure to support current or future alternative fuel vehicle use.

Compliance: Inspected (**5:** Final).

12.3 Location-Efficient Project**3 points**

Locate a project within a ¼ mile radius of a transit stop.

Compliance: Inspected (**PC:** Plan Check).

12.4 Ground source heat pumps with wind power**15 Points**

Purchase wind power for 50% of the estimated electricity consumed with a ground source heat pump for heating and cooling for 20 years. Wind powered electricity shall be purchased off-site through a payment to the REMP fund. Calculation of payment shall be as follows:

Annual electricity consumption (Kilowatt hours) x 50% x \$.025/kilowatt hour X 20 years.

Compliance: Inspected (**5:** Final).